

**Glow·worm**

# **Clearly Solar**

## **Solar Thermal Flat Plate Collector Installation Instructions**

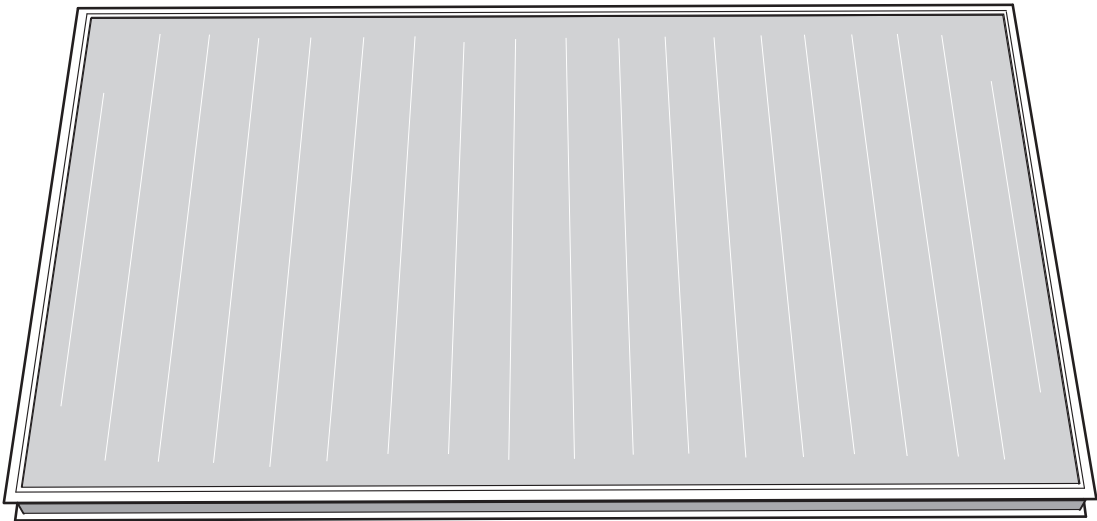

**Horizontal On-roof mounting  
15° - 75°  
SRH 2.3**

# Guarantee Registration

---

These Clearly Solar Flat Plate collectors come with a comprehensive manufacturer's guarantee. Details of the guarantee, and the terms and conditions that apply can be found on the Guarantee registration card. We recommend you complete and return this as soon as possible.

## **Customer Service:**

01773 596510

## **Technical Helpline:**

01773 828300

## **General and Sales enquiries:**

Tel. 01773 824639

Fax: 01773 820569

## **To register your Glow-worm appliance call:**

0800 0732142

Benchmark places responsibilities on both manufacturers and installers. The purpose is to ensure that customers are provided with the correct equipment for their needs, that it is installed, commissioned and serviced in accordance with the manufacturer's instructions by competent persons and that it meets the requirements of the appropriate Building Regulations. The Benchmark Checklist can be used to demonstrate compliance with Building Regulations and should be provided to the customer for future reference.

Installers are required to carry out installation, commissioning and servicing work in accordance with the Benchmark Code of Practice which is available from the Heating and Hotwater Industry Council who manage and promote the Scheme.

Visit [www.centralheating.co.uk](http://www.centralheating.co.uk) for more information.



These instructions must be handed to the user on completion of the installation.

CONTENTS	DESCRIPTION	SECTION	PAGE
<b>GENERAL INFORMATION</b>	Warnings		4
	Important Information		4
	Statutory Requirements		5
<b>TECHNICAL SPECIFICATION</b>	Technical Specification	1	6
	Technical Data	2	7
<b>ROOF MOUNTING</b>	Solar Collector and Hydraulic Connection Arrangement	3	8
	Hydraulic Connection Kits	4	9
	Roof Anchor - Type P	5	10
	Roof Anchor - Type S	6	12
	On-Roof Installation	7	13

# WARNINGS

## **Metal Parts**

This solar panel contains metal parts (components) and care should be taken when handling, with particular regard to edges.

## **Risk of death from falls and falling objects**

Observe the national regulations for working at heights.

## **Danger of burning and scalding**

In case of solar irradiation inside the units, solar panels can reach 200°C.

Remove the sun protection film installed at the factory only after the solar energy system has been started up.

## **Sealed Components**

Under no circumstances must the user interfere with or adjust sealed parts.

## Important Information

### **General**

These instructions must be handed to the user on completion of the installation.

This installation instruction applies exclusively to the on-roof mounting of the Clearly Solar, solar collector panel.

The solar collector panel is one component in a solar system and it is recommended that you read all other component(s) literature prior to installation.

We accept no liability for any damage caused by failure to observe these instructions.

### **Manual Handling**

With regards to the "Manual Handling Operations, 1992 Regulations", this product exceeds the recommended weight for a one man lift.

Recommend 2 person lift. Ensure safe lifting techniques are used – keep back straight – bend using legs. Keep load as close to body as possible. Ensure co-ordinated movements during lift. Clear the route before attempting the lift. If removing from truck straddle the load and tilt forwards to facilitate secure grip. Do not twist – reposition feet instead. Take care to avoid trip hazards, slippery or wet surfaces and when climbing steps or ladders. Always use assistance if required.

Installation of the solar collector panel will require a risk assessment.

### **Testing and Certification**

This solar collector panel is tested and certificated for safety and performance. It is, therefore, important that no alteration is made, without permission, in writing, by Glow-worm.

Any alteration not approved by Glow-worm, could invalidate the certification, warranty and may also infringe the current issue of the statutory requirements.

### **CE Mark**

The CE mark on the solar collector panel indicates that it complies with the basic requirements of the applicable directives as stated on the data badge.

### **Damage from lightning**

If the installation height is more than 20m or if the solar panels are projected above the roof ridge, electro-conductive components must be connected to a lightning protection device.

### **Frost Protection**

Under no circumstances should water be in the solar collector panel if there is a danger of frost.

After pressurisation and flushing, the solar collectors panels may contain water residues.

Immediately fill the solar system with solar fluid. Check the fluid concentration with a frost protection tester. Water remaining in the solar circuit may dilute the fluid.

# Statutory Requirements

## IMPORTANT

Where no British Standards exists, materials and equipment should be fit for their purpose and of suitable quality and workmanship.

The installation of this solar collector panel must be carried out by a **competent person** in accordance the rules in force in the countries of destination.

Manufacturer's instructions must not be taken as overriding statutory requirements.

## Statutory Requirements

In GB, the installation of the solar collector panel must comply with the requirements of the current issue of the following regulations:

The manufacturer's instructions supplied.

The appropriate Buildings Regulations either The Building Regulations, The Building Regulations (Scotland), The Building Regulations (Northern Ireland).

Working at Heights Regulations 2005.

Connecting thermal solar appliances.

Lightning protection requirements.

Equipotential bonding of electrical installations.

The Health and Safety at Work Act

Control of Substances Hazardous to Health (COSHH).

The Current I.E.E. Wiring Regulations.

The Water Supply (water fittings) Regulations 1999 or the Water Byelaws 2000 (Scotland).

Where no specific instructions are given, reference should be made to the relevant British Standard Code of Practice.

## Regulations for the prevention of accidents

At all times follow the national regulations on working at heights.

Make sure there is suitable safety equipment such as scaffolding or protective walls to prevent falling from roofs.

Fall protection systems such as the Glow-worm fall protection system (item no. 0020054985) also has a fall arresting device if the roof scaffold and protective roof wall are inappropriate for the specific task.

Only use tools and equipment such as lifting gear or ladders in accordance with the lifting regulations.

Cordon off areas below the working area sufficiently to protect people from falling objects.

Mark the working area, for example with warning signs as described by the national regulations.

# 1 Technical Specification

## Design Description

The Clearly Solar, solar flat plate collector, collects the available solar radiation and transfers the heat through the solar fluid to be utilised by the system.

It has been designed to compliment the complete range of Glow-worm solar system components.

The kits are suitable for roof pitches between 15° - 75°, please choose from the table below.

The solar thermal flat plate collector includes a saltwater-resistant aluminium frame as well as a copper surface absorber with a high selective coating.

The flat plate collector has a CFC-free, standstill temperature-resistant mineral wool insulation for long-life and excellent heat insulation.

Hydraulic connections are tool free with double 'O' ring sealing. The sensor sleeve is integrated into the hydraulic flow connection.

The following kits are available and dependant upon the number of collectors, the quantities required are listed in the following tables and illustrated in the appropriate sections:-

### On-roof installation components

<b>High profile tiled roof (pantile)</b>										
<b>Number of collectors</b>	<b>1</b>	<b>2</b>	<b>3</b>	<b>4</b>	<b>5</b>	<b>6</b>	<b>7</b>	<b>8</b>	<b>9</b>	<b>10</b>
Type P anchor part no. 0020060302 - Section 5	1	2	3	4	5	6	7	8	9	10
Easy fit hydraulic connection set part no. 0020060207	1	1	1	1	1	1	1	1	1	1
Easy fit hydraulic extension set part no. 0020055175	-	1	2	3	4	5	6	7	8	9
Collector panel	1	2	3	4	5	6	7	8	9	10

<b>Low profile tiled roof (slate)</b>										
<b>Number of collectors</b>	<b>1</b>	<b>2</b>	<b>3</b>	<b>4</b>	<b>5</b>	<b>6</b>	<b>7</b>	<b>8</b>	<b>9</b>	<b>10</b>
Type S anchor part no. 0020055184 - Section 6	1	2	3	4	5	6	7	8	9	10
Easy fit hydraulic connection set part no. 0020060207	1	1	1	1	1	1	1	1	1	1
Easy fit hydraulic extension set part no. 0020055175	-	1	2	3	4	5	6	7	8	9
Collector panel	1	2	3	4	5	6	7	8	9	10

## 1.1 On-roof mounting

With on-roof mounting, flat collectors are fastened to horizontal mounting rails quickly and reliably with attachment clips. To ensure compatibility with different roofings, two different roof anchors are available:

- Type P for high profile (pantile)
- Type S for flat profile (slate) and extremely high protruding tiles (e.g. Mediterranean clay tiles).

## 2 Technical Data

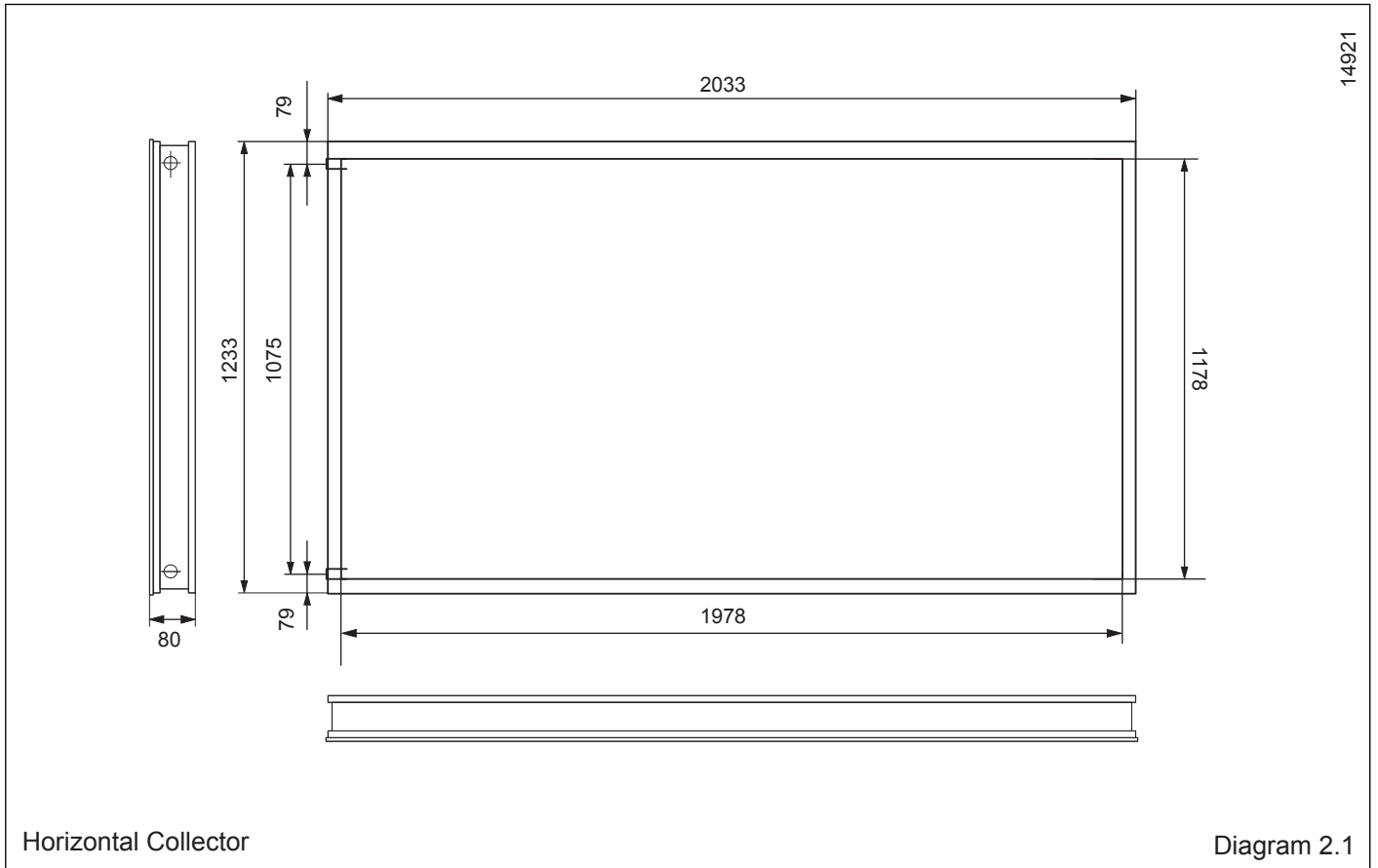

14921

Appliance designation	Unit.	Clearly Solar	
Absorber type		Serpentine	
Gross area	m <sup>2</sup>	2.51	
Aperture surface area	m <sup>2</sup>	2.35	
Absorber surface area	m <sup>2</sup>	2.33	
Absorber		Aluminium (vacuum coated) 0.5 x 1178 x 1978	
Dimensions (L x W x H)	mm	1233 x 2033 x 80	
Weight (Dry)	kg	38	
Fluid content	l	2.16	
Copper pipe connection, flat-face	Ø mm	G 3/4" (DN16)	
Insulation thickness	mm	40	
Max. operating pressure	bar	10	
Glass type		Solar safety glass (prismatic structure)	
Glass covering	mm	3.2 (thickness) x 2033 x 1233	
Coating		High selective (blue)	$\alpha = 95\%$ $\varepsilon = 5\%$
Solar safety glass transmission $\tau$ (dew)	%	$\tau = 91$	
Absorber emission $\varepsilon$ (epsilon)	%	$5 \pm 2$	
Back wall insulation	mm, W/mk, kg/m	$95 \pm 2$	
Stagnation temperature	°C	210	
Efficiency $\eta_0$	%	80	
Heat capacity	Ws/ (m•K)	5014	
Efficiency coefficient k1	W/(m <sup>2</sup> •K)	3.7	
Efficiency coefficient k2	W/(m <sup>2</sup> •K <sup>2</sup> )	0,012	

# 3 Solar Collector and Hydraulic Connection Arrangement

## Solar Collector

The recommended collector arrangements are shown below.

## Hydraulic Connections

It is recommended that the hydraulic connections should be made as shown below.

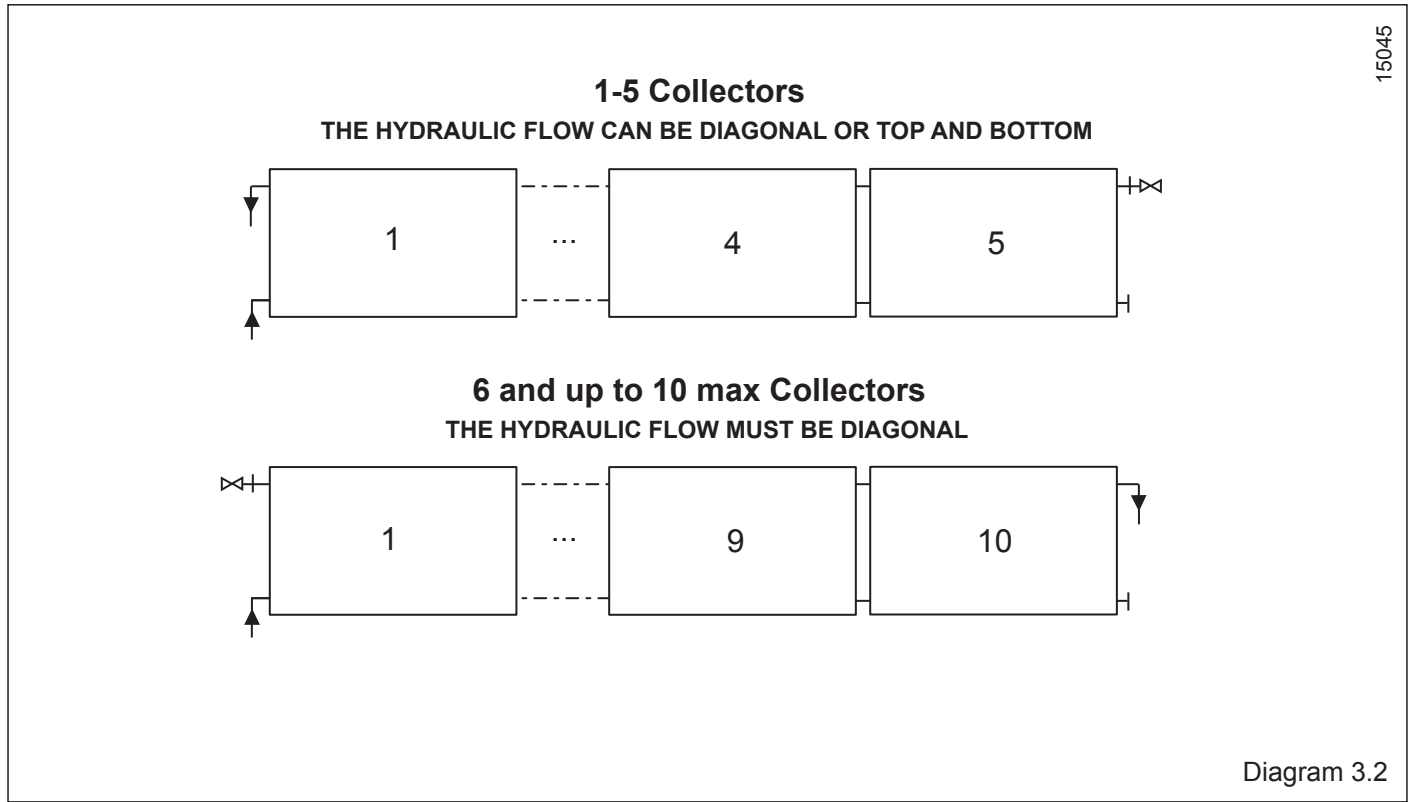



# 4 Hydraulic Connection Kits

15188

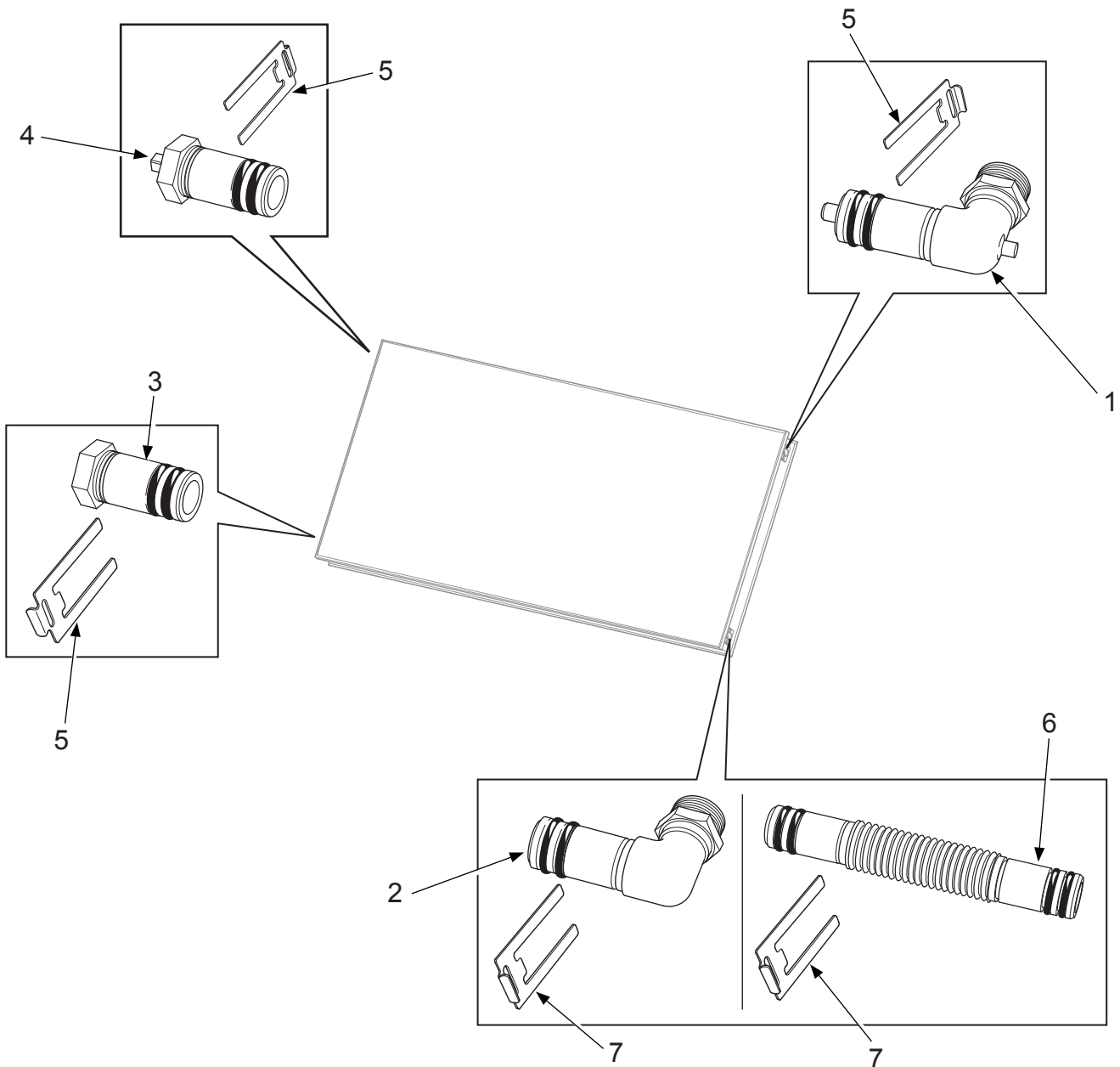

Easy fit hydraulic connection set - Kit No. 0020060207		
Part	Description	Qty.
1	Upper supply (with probe)	1
2	Return (inlet)	1
3	Lower plug	1
4	Upper plug (with ventilation)	1
5	Securing clip	4
Easy fit hydraulic extension set - Kit No. 0020055175		
Part	Description	Qty.
6	Pipe coupling	2
7	Securing clip	4

Diagram 4.1

# 5 Roof Anchor - Type P

	Distance in millimetres
<b>A</b>	1233
<b>B</b>	200 - 300
<b>C</b>	1433 - 1633

15186

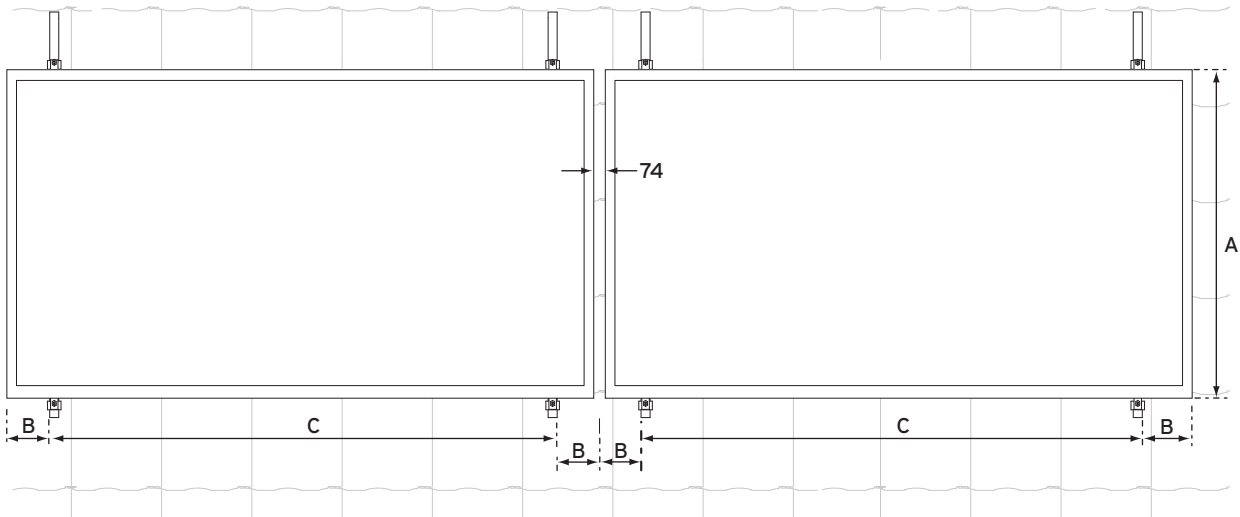
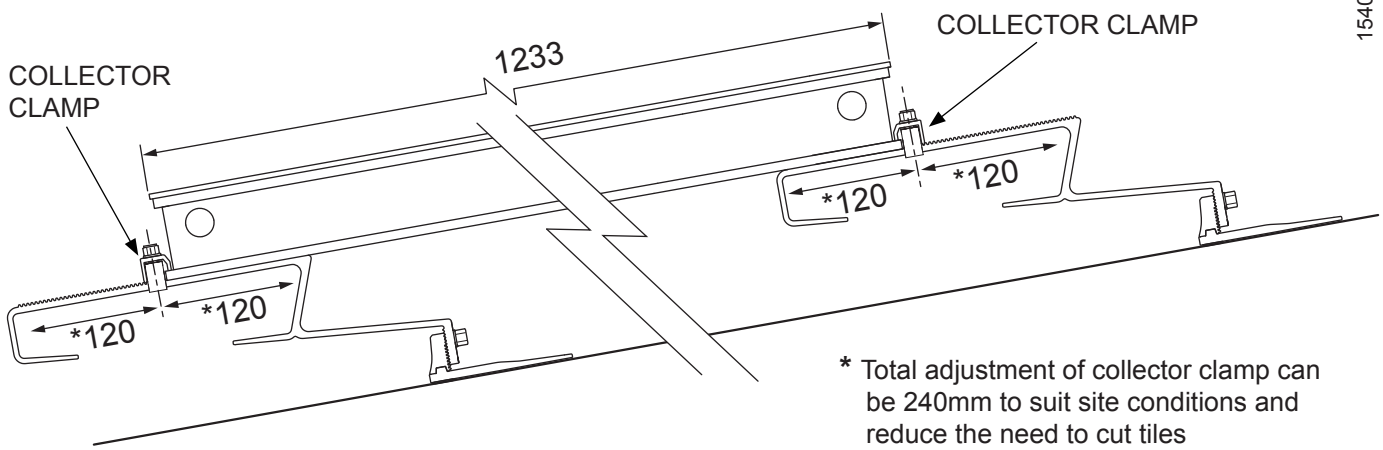
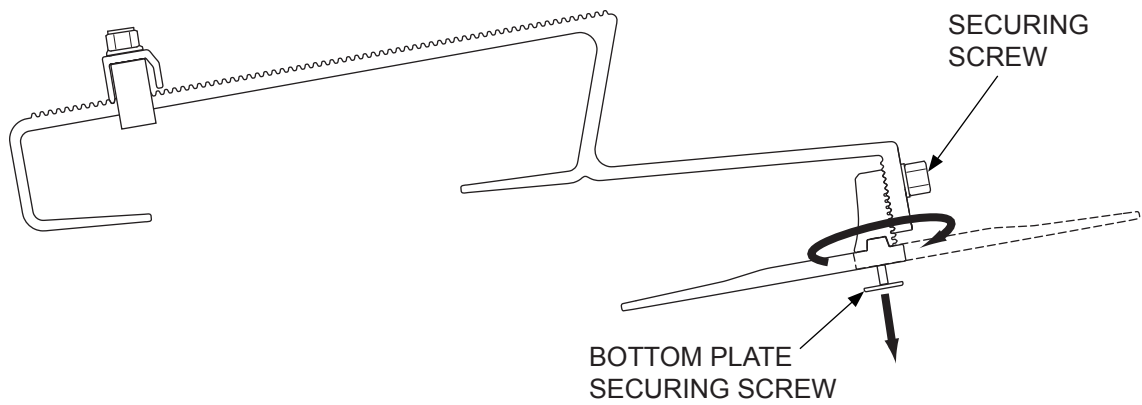

Diagram 5.1

15153



\* Total adjustment of collector clamp can be 240mm to suit site conditions and reduce the need to cut tiles

15408

ROOF ANCHOR TYPE P

Diagram 5.2

# 5 Roof Anchor - Type P

## IMPORTANT

- With due regard to the complete weight of the solar collector system, (refer to technical data) ensure the roof rafters and battens are in good condition and have sufficient load carrying capacity and the battens are secure.

## 5.1 Fixing roof anchor type P

Remove the roof tiles to expose the roof battens and rafters where required, please refer to diagram 5.1 and 5.2 for position of brackets.

If required loosen the securing screw, see diagram 5.2.

Using a 5mm Allen key, release the bottom plate securing screw and swivel 180° and secure.

Position the roof anchor on the rafter, see diagram 5.3.

Ensure that the roof anchor is secured to the rafter with the screws supplied.

Re-position the tiles ensuring that the roof is water tight before fitting the collector.

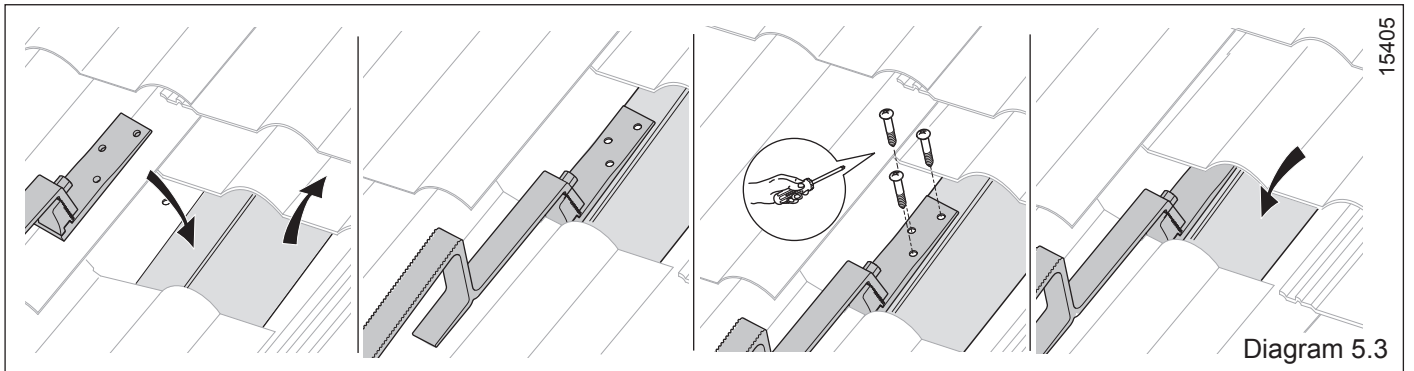

# 6 Roof Anchor - Type S

## IMPORTANT

- With due regard to the complete weight of the solar collector system, (refer to technical data) ensure the roof rafters and battens are in good condition and have sufficient load carrying capacity and the battens are secure.

## 6.1 Roof anchor type S

Refer to diagram 6.1.

Remove the tiles where required, refer to diagram 5.1.

The roof anchor must be secured to a rafter.  
Ensure that the roof anchor is secured with the screws supplied.

Slide the tiles back to their original position.

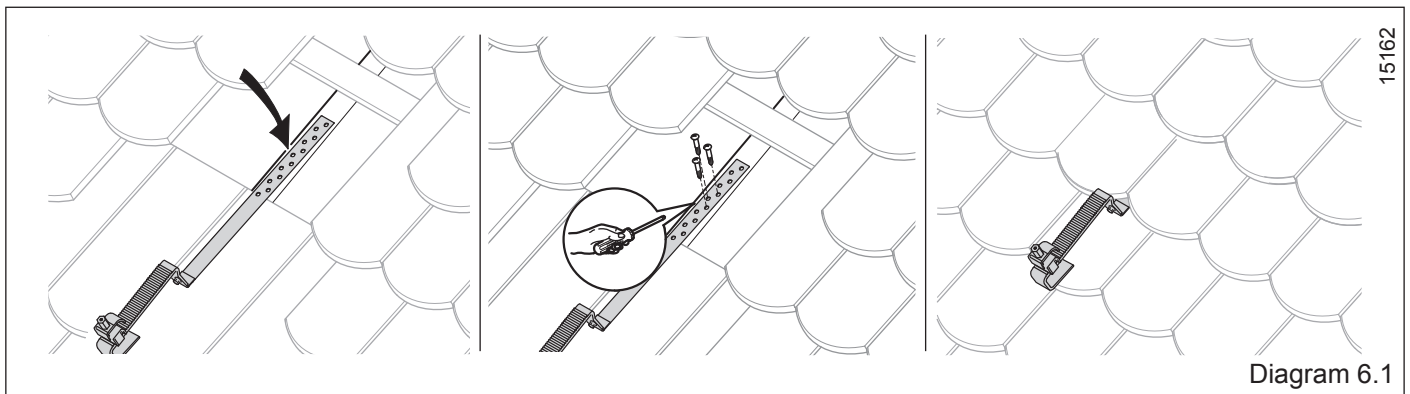

# 7 On-Roof Installation

## 7.1 Collector installation

Ensure the mounting brackets are level before securing, see diagram 7.1.

Position the collector, protective side uppermost, on the mounting bracket and beneath the clamp, see diagram 7.2.  
**NOTE:** The design is symmetrical and does not have a top or bottom.

**IMPORTANT:** Do not remove the protective film until the system is to be commissioned

Move the clamp into position ensuring the correct engagement of both clamps onto the collector.

Secure the clamps.

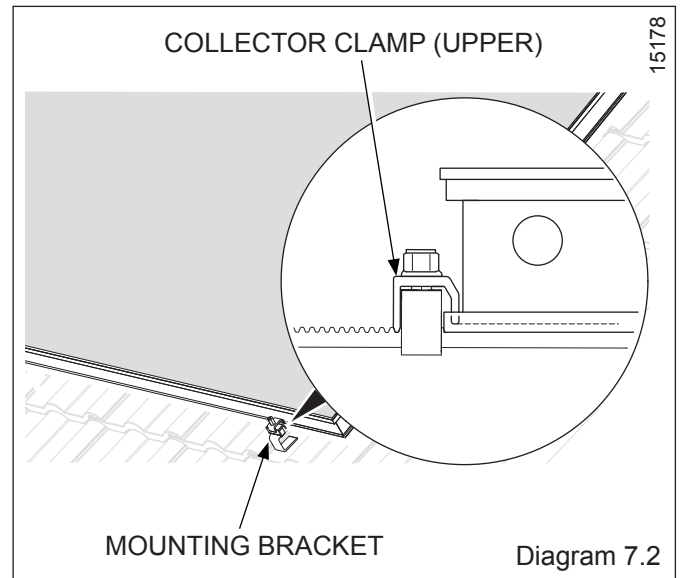
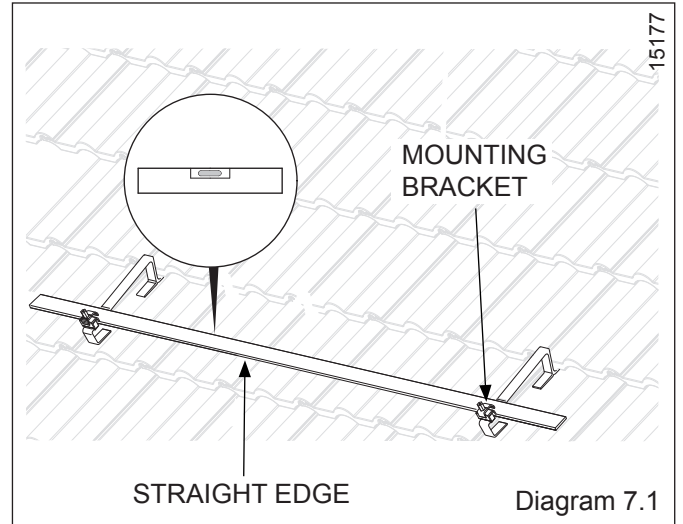

# 7 On-Roof Installation

Insert the pipe couplings up to the limit stop into the corresponding openings on the side of the collectors, see diagram 7.3.

Secure the pipe coupling with the securing clip

Place the next collector on the lower mounting bracket. Slide the collector up to the first collector paying attention to the pipe couplings, see diagram 7.4.

When fully inserted to the limit stops, ensure that the pipe couplings are secured with the securing clips.

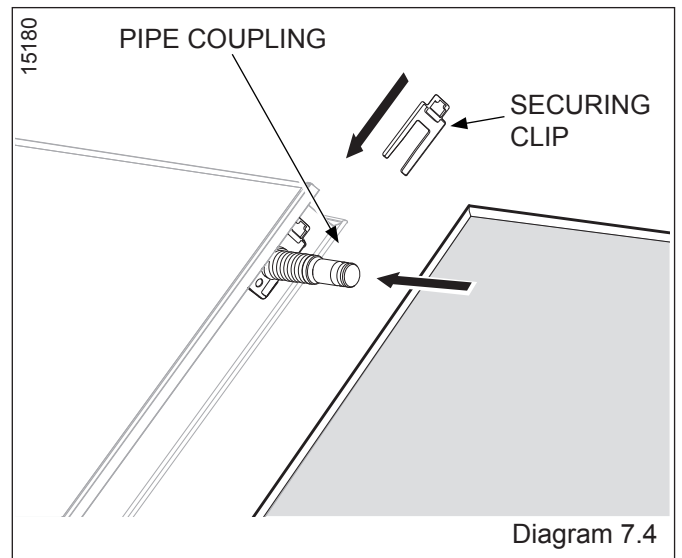
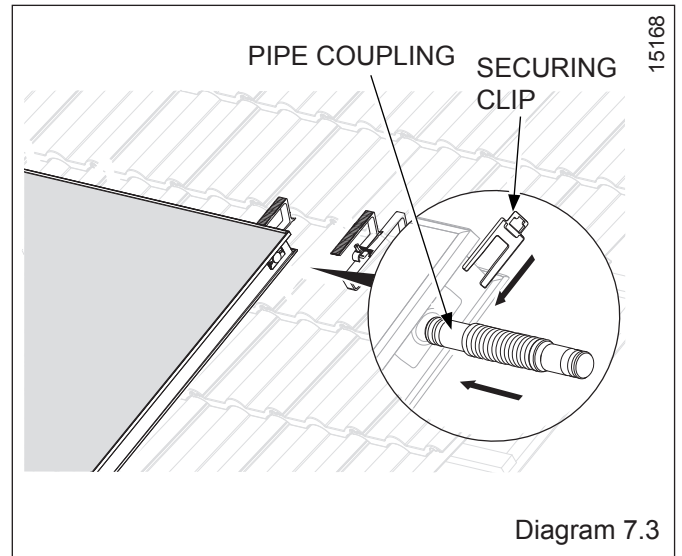

# 7 On-Roof Installation

With regards to the hydraulic system you have chosen, insert and secure the hydraulic connections, see diagrams 7.5 and 7.6.

Connect the collector Flow and Return to the system circuit.

Ensure that all of the following steps have been performed:-

- All the connections have been fixed with securing clips.
- All hydraulic connections laid properly.
- The collector sensor has been connected.
- The collectors are connected to a lightning protection device.
- A pressure test carried out and all connections are tight.
- All insulation is intact.

**NOTE:** After initial commissioning and according to the season, high outside temperature oscillations can cause condensation in the collector, this is normal.

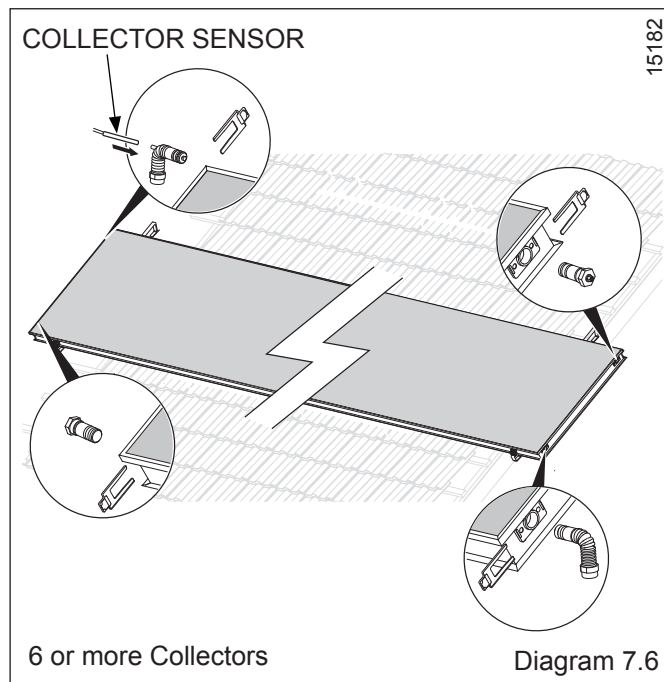
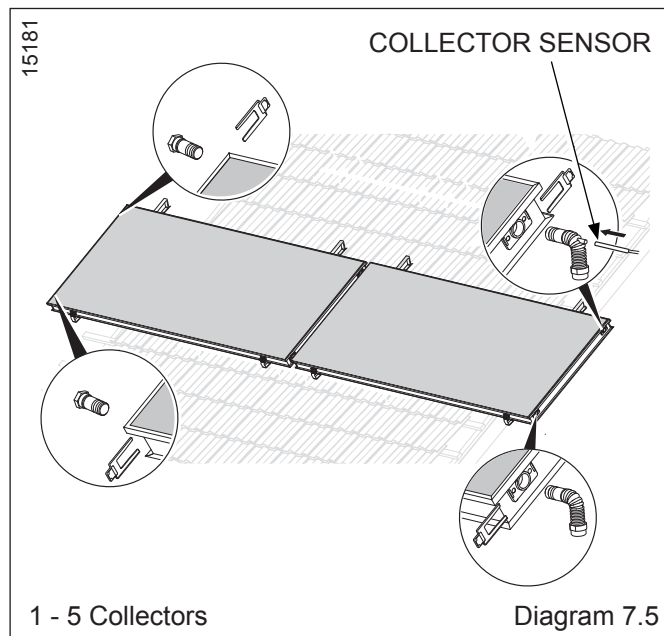

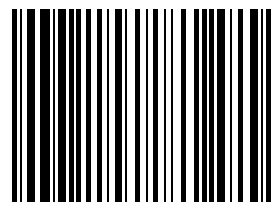

0020080932

*Because of our constant endeavour for improvement, details  
may vary slightly from those shown in these instructions.*

**Glow-worm**, Nottingham Road, Belper, Derbyshire. DE56 1JT